

# Compact Lock Jig

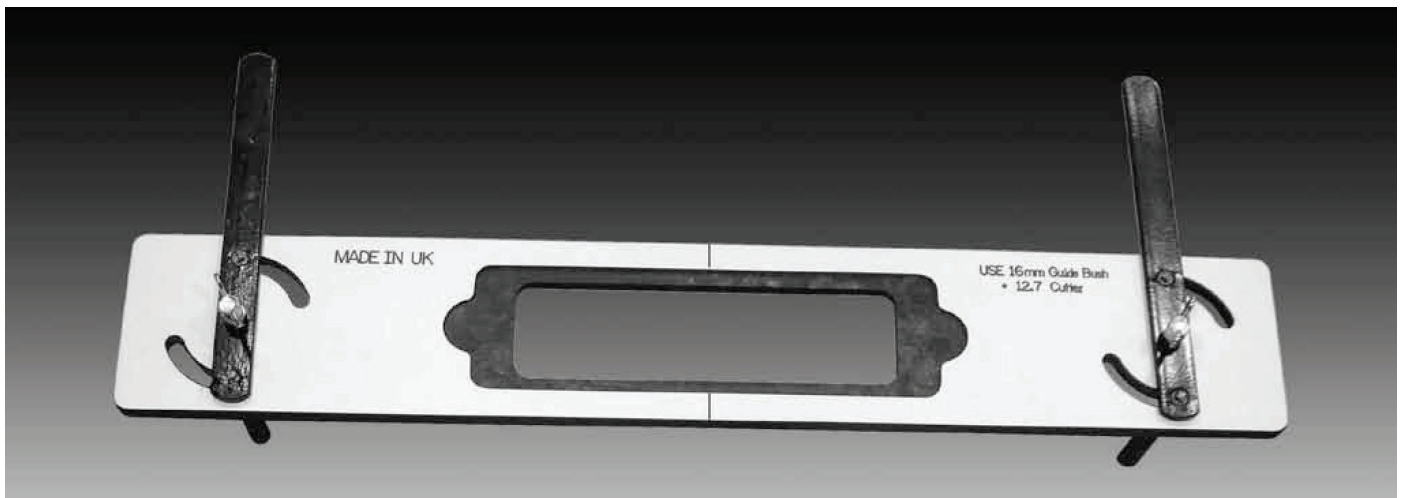

## Key Features:

- Unika Lock Jig is designed to cut the mortise and face plate recesses for popular door locks.
- The lock jig uses a set of interchangeable laminate templates which can be used to cut the following sizes:

Face Plate: 6" x 1"  
43/4" x 1"  
21/4" x 1"

Lock Body: 41/4" x 3/4"  
3" x 3/4"  
7/8" x 5/8"

- Deep mortises can be achieved with a suitable size of auger bit.
- Unika Lock Jig produces quick, clean and accurate results on doors (including hardwood) 34mm to 58mm thick.

## Contents:

Jig Plate (600mm x 100mm)  
X2 Self Centring clamps

## Other Equipment Required:

Light Duty Router (900 – 1000 W)  
16mm Guide Bush  
12.7mm Cutter

## Directions for Use:

Follow instruction manual.

## Consumer Benefits:

Designed in conjunction with fitters the Unika Lock Jig is precision engineered to the highest standards.

Small single piece jig means it is easy to store and transport to jobs.

Self centring when clamped to the door.



## Product Advantages:

Machined on the latest CNC machine using diamond cutters for accuracy and a smooth finish.

Made from 12mm hardwearing compact laminate, it is guaranteed never to warp.

## Retailer Opportunity:

Small and compact means its easy to transport to jobs but still carries out all the main lock cuts.

## UNIKA COLOR PRODUCTS LTD

Unika House, New York Way, New York Industrial Park,  
Newcastle upon Tyne, U.K. NE27 0QF

Telephone: +44 (0) 191 259 0033

Fax: +44 (0) 191 257 4525

Email: sales@unika.co.uk www.unika.co.uk

