

TopMarker

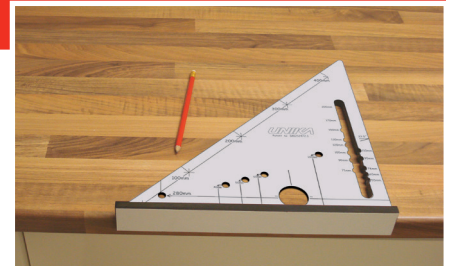

Product: TopMarker

Features & Benefits

- Most new kitchens require an accurate sink and hob cut out before installation of the appliance. Traditionally the kitchen fitter will use a tape measure and straight edge along with a jigsaw to carry out this task. TopMarker is a brand new tool that makes this job more efficient and consistent.
- TopMarker will assist the kitchen fitter to cut out an accurate aperture in which to fit a sink and hob. It works with a range of worktop widths.
- TopMarker can also be used to mark measurements for the placement of door handles.
- Use it to mark out a 45° angle on your worktop - internal or external.
- If the hob is to be fitted in a corner situation there is a 22.5° angle.
- TopMarker is made from 13mm Compact Grade Laminate and is guaranteed never to warp.
- **NEW** TopMarker has a 35mm Hinge hole cut out. This can be used in conjunction with a drill and 35mm Hinge Cutter for easy cut out with no drill slip/movement. The Hinge Hole is also set in 22.5mm, so it is ready to go once clamped into place.

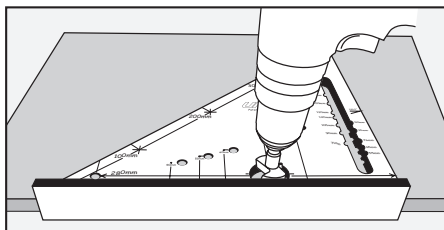

- It is a handy kitchen fitters tool for efficient and consistent cut outs. No measuring, marking, levelling and then rechecking all measurements. Use TopMarker and mark out and cut with confidence first time.

Directions for use:

- TopMarker is to be used on the leading edges of the front or back of the worktop
- The specified markings relate to standard cut out sizes required eg. a standard hob of 560 x 480mm or sink of 930 x 480 - 485mm
- Other measurements are located on the marker for different size cut outs.

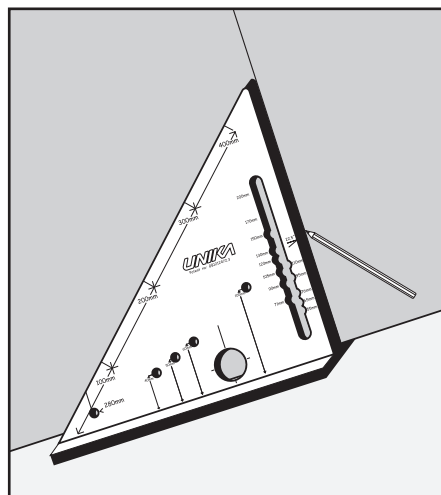

- To obtain the 560mm Width for a hob place the TopMarker on the front edge and use the 280mm hole from the centre line. The marker will have to be turned over to draw the markings for the right side eg. from the centre of the hob 280mm to the left and 280mm to the

right totalling the 560mm requirement. The marker can be turned around and lined up across the back of the worktop to extend this line.

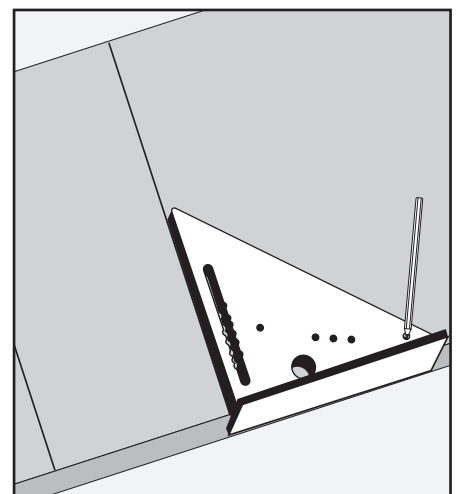
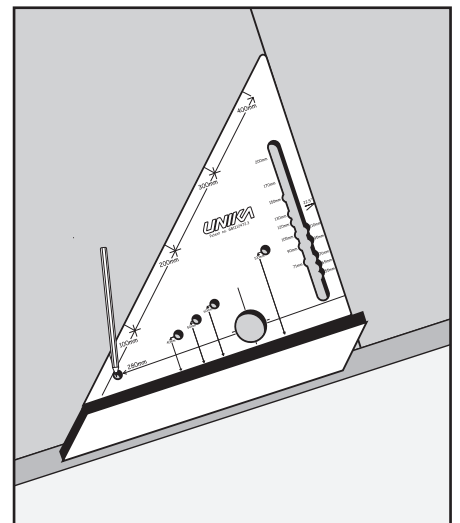

UNIKA COLOR PRODUCTS LTD

Unika House, New York Way, New York Industrial Park,
Newcastle upon Tyne, U.K. NE27 0QF

Telephone: +44 (0) 191 259 0033

Fax: +44 (0) 191 257 4525

Email: sales@unika.co.uk www.unika.co.uk



The mark of responsible forestry



PEFC/16-33-1158



001



001



001

TopMarker

- To obtain the 480mm depth of hob/sink place the TopMarker on the front edge of any standard worktop eg. 40mm thick x 600mm.
- Use the specified holes on the marker to locate the front edge markings for cut out.

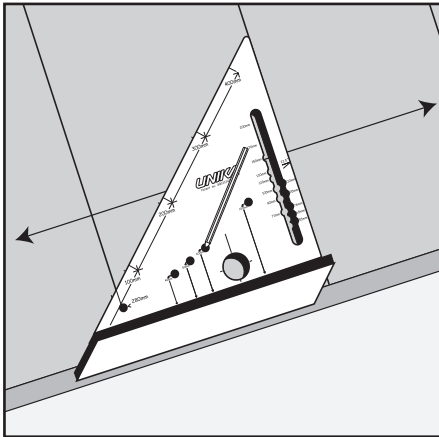

Use the pre-determined measurements on the measurement slot for the back marking.

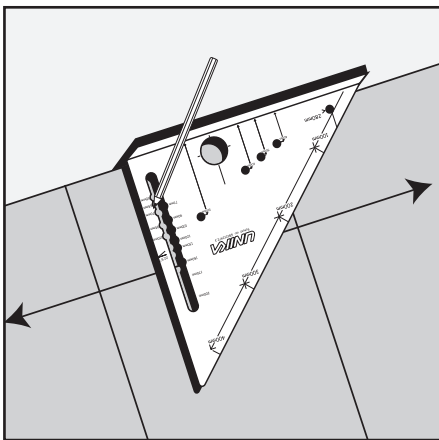

Use a marker pen to draw these lines.

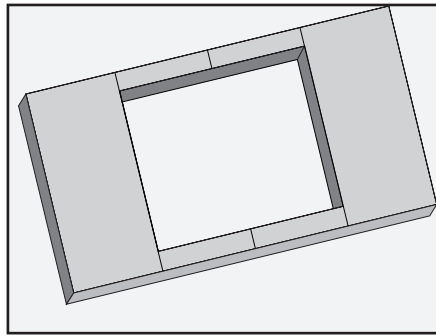
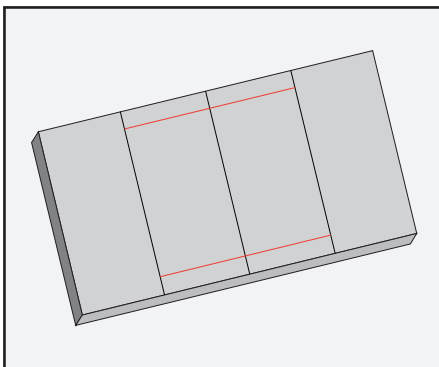

See below for examples:

600mm Worktop – 480mm Hob/Sink – Use 60mm hole for front edge & 60mm hole for back edge.

616mm Worktop – 480mm Hob/Sink – Use 60mm hole for front edge & 76mm mark for back edge.

650mm Worktop – 480mm Hob/Sink – Use 60mm hole for front edge & 110mm mark for back edge.

600mm Worktop – 485mm Sink – Use 60mm hole for front edge & 55mm mark for back edge.

616mm Worktop – 485mm Sink – Use 60mm hole for front edge & 71mm mark for back edge.

650mm Worktop – 485mm Sink – Use 60mm hole for front edge & 105mm mark for back edge.

- TopMarker can be used to mark out a corner 45° worktop cut (internal or external).

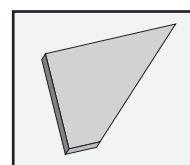
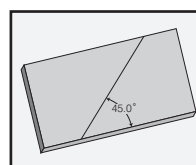
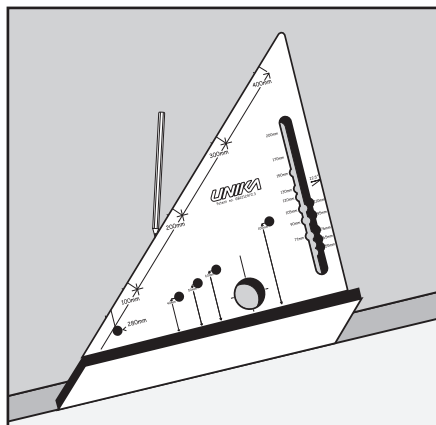

- There is also a 22.5mm angle that can be used if the hob is being fitted in a corner situation.

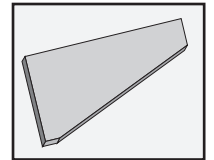
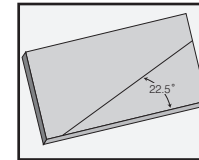
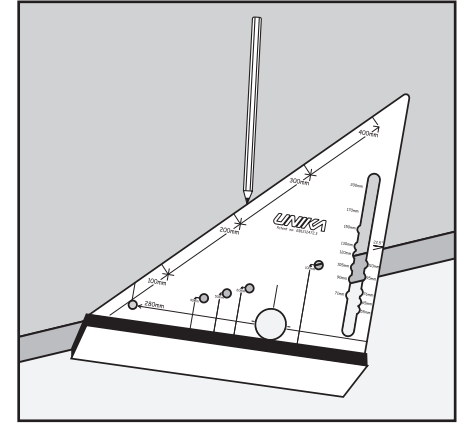

- Use the 40mm hole to mark measurements for the placement of handles on doors eg. 40mm in from the leading edge of the door.

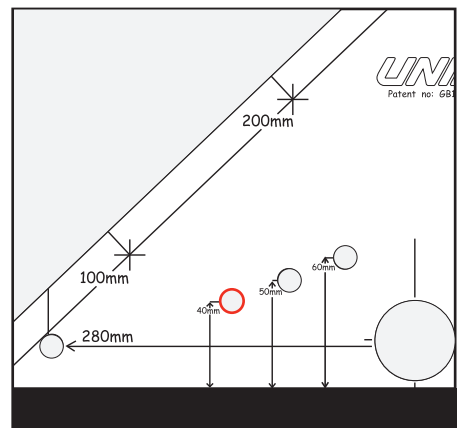

Retailer Opportunity:

- A handy time saving device for all Kitchen Fitters
- Makes all cut outs quick to perform and with a uniform result.

UNIKA COLOR PRODUCTS LTD

Unika House, New York Way, New York Industrial Park, Newcastle upon Tyne, U.K. NE27 0QF

Telephone: +44 (0) 191 259 0033

Fax: +44 (0) 191 257 4525

Email: sales@unika.co.uk www.unika.co.uk



The mark of responsible forestry



PEFC/16-33-1158



001



001



001



001